

## Self Priming Lift Station

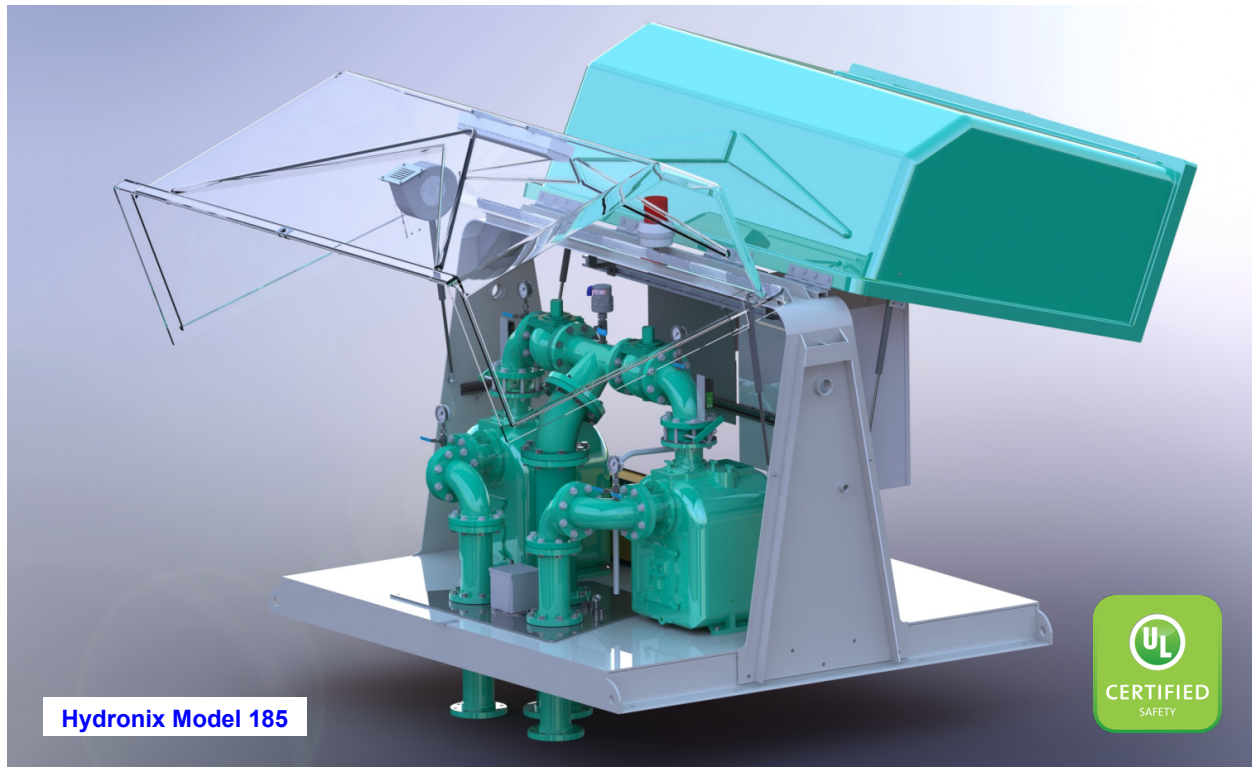

Hydronix Model 185

The 180 Series, self priming lift stations have been one of our most popular products for over thirty years. They are a good alternative when a wet well cannot be sized for submersibles or when ease of maintenance is a high priority. Almost 100% of the system components including, pumps, motors, piping, valves and controls are installed inside the gull wing enclosure. All are easily accessible and confined space entry is not an issue.

The enclosure can be installed directly over an existing wet well or a new, fiberglass wet well can be provided as part of the package. A broad range of self priming, solids handling pumps are available in both close coupled and belt driven configurations. Applications that are

prone to plugging can upgrade to self priming, chopper pumps.

### Standard Features:

- 3" to 8" standard self primers or choppers
- Fiberglass, gull wing design allows easy access & eliminates confined space requirements
- Insulated or standard lids
- Optional space heater
- Corrosion resistant galvanized skids
- Ductile iron piping
- Valves (check / plug / air release) & gauges
- Control panel with touch screen display
- Optional iRover remote control via your iPad
- Float, transducer & ultrasonic level options
- Complete Package UL QCZJ listed

## Hydromatic Self Priming Non-Clog

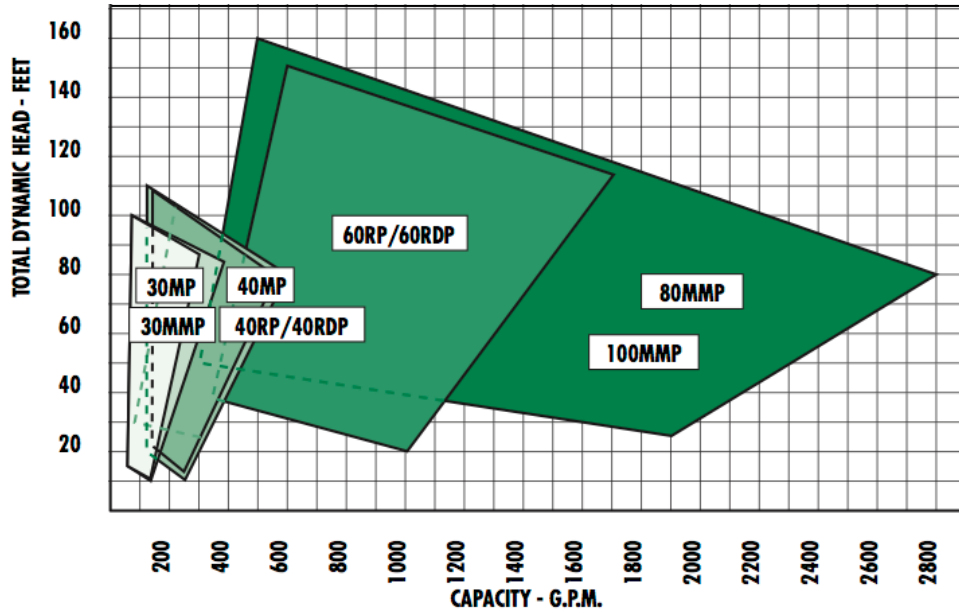

## Vaughan Self Priming Chopper

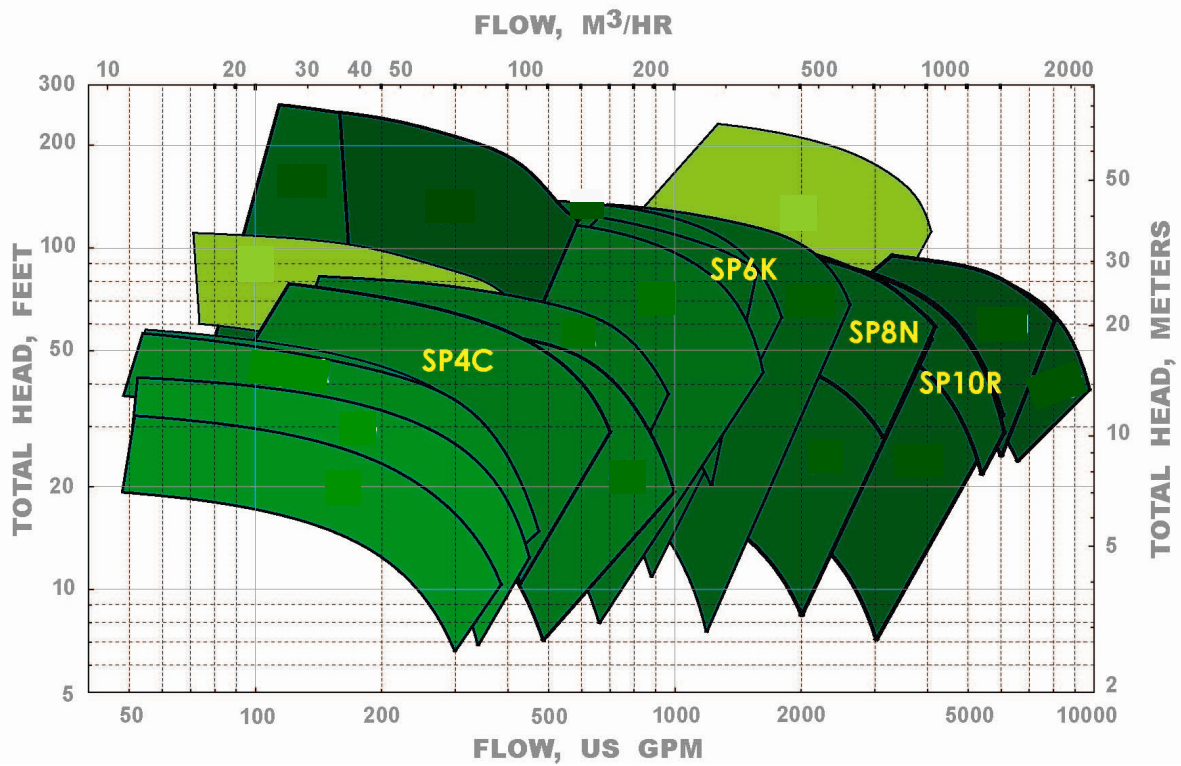

9 / 2013



A Division of PumpTech Inc.  
503-659-6320  
Inquiries@pumptechnw.com



PumpTech Inc.  
TOLL FREE: 888-644-6686  
www.pumptechnw.com